

NOTES:

**IMPORTANT
SEE PAGES
34 & 35
FOR
INSTRUCTIONS**

CHEM-TAINER
INDUSTRIES INC.

FAX NO. 516-661-8209

TANK CAPACITY: _____
TANK D."X H.": _____ " X _____ "
TANK STYLE SELECTED: _____
DATE: _____ REF. NO.: _____

TANK STYLE

**IA
IC
IX**

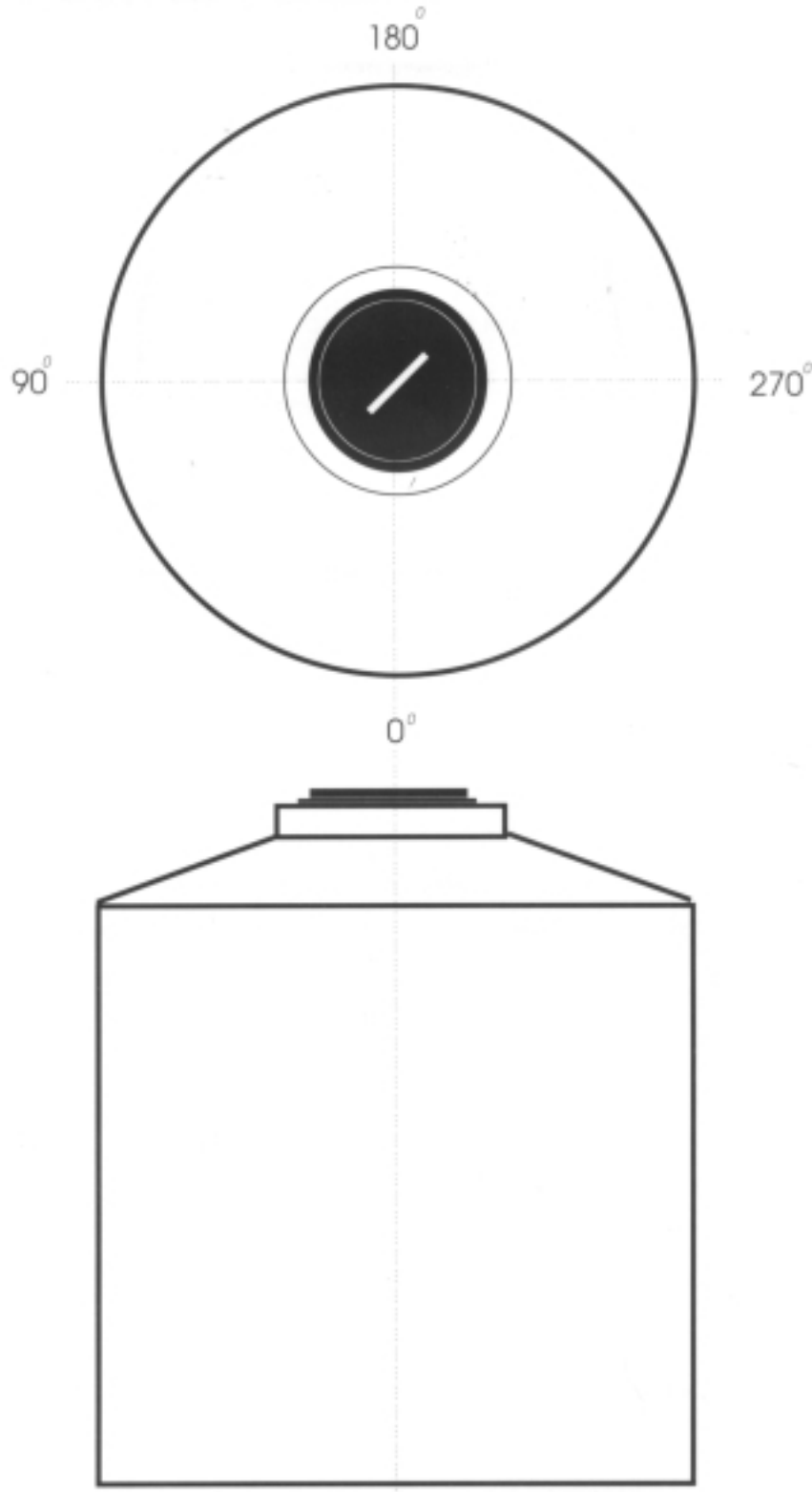

NOTES:

**IMPORTANT
SEE PAGES
34 & 35
FOR
INSTRUCTIONS**

CHEM-TAINER
INDUSTRIES INC.

FAX NO. 516-661-8209

TANK CAPACITY: _____
TANK D." X H.": _____ " X _____"
TANK STYLE SELECTED: _____
DATE: _____ REF. NO.: _____

TANK STYLE

**IA
IC
IX**